

MP-32PG Planetary Gear motor MAX – MOTOR



Main voltage: 3VDC、6VDC、9VDC、12VDC、24VDC、

Typical applications: Auto shutter, Micro CNC equipment, Central air-conditioning valve, Robots, Towel dispensers, Limelight, Automatic closet bowl special valve, Electric advertising, Angular telescope, Office equipment, Household appliances, Automatic actuator.

Weight: 180~230g/pcs (approx)

Packing details: CTN size: 36.5X31XH17cm 60pcs/CTN G.W.13Kgs

APPEARANCE SIZE

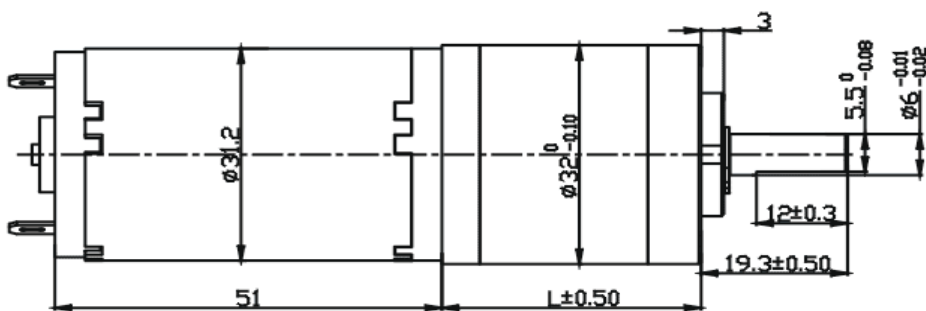
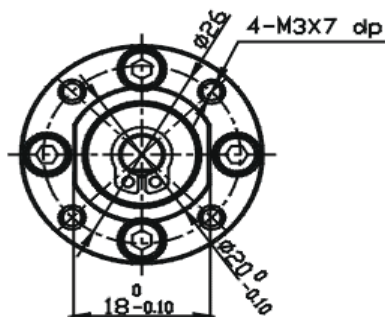

Gearbox data:

Number of stages	1 stages reduction	2 stages reduction	3 stages reduction	4stages reduction	5stages reduction
Reduction ratio	3.35, 4.63	11.22, 15.51, 21.44	37.60, 51.96, 71.81, 99.25	125.94, 174.07, 240.58, 332.50, 459.54	421.91, 583.12, 805.93, 1113.87, 1539.46, 2127.67
Gearbox length "L" mm	20.7	26.4	32.2	38	43.8
Max. Running torque	2.0Kgf • cm	3.0Kgf • cm	4.0Kgf • cm	6.0Kgf • cm	10Kgf • cm
Max. Gear breaking torque	6.0Kgf • cm	9.0Kgf • cm	12Kgf • cm	18Kgf • cm	30Kgf • cm
Max. Gearing efficiency	90%	81%	73%	65%	59%

Motor data:

Motor name	Rated Volt. V	No load		Load torque				Stall torque	
		Current	Speed	Current	Speed	Torque	Output power	Torque	Current
		mA	r/min	mA	r/min	gf • cm	W	gf • cm	mA
31ZY123000	12	≤100	3000	≤400	2200	90	2.0	360	1600
31ZY124500	12	≤150	4500	≤700	3300	130	4.3	520	2700
31ZY126000	12	≤220	6000	≤1200	4500	180	8.0	720	5000
31ZY243000	24	≤60	3000	≤200	2200	90	2.0	360	800
31ZY244500	24	≤90	4500	≤350	3300	130	4.3	520	1300
31ZY246000	24	≤130	6000	≤650	4500	180	8.0	720	2600

1. This table lists some motors parameters, others please refer to specific parameters of Page150.
2. After connecting motor and gearbox which is named gearmotor the output torque: motor torque X reduction ratio X gearing efficiency; output speed: motor speed / reduction ratio.