

# 混合式步进电机 HYBRID STEPPING MOTOR

## 39BYGHM



### 详细说明 General Specifications

Step Accuracy	± 5%
Temperature Rise	80°C Max
Ambient temperature Range	-20°C~+50°C
Insulation Resistance	100MΩ Min.500V DC
Dielectric Strength	500V AC 1 minute

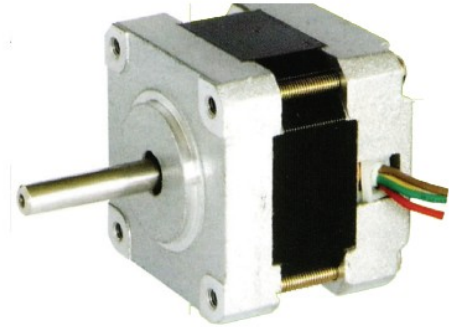

### 技术数据 Electrical Specifications

电机型号 Model	步距角 Step angle (°)	机身長 Motor Length L(mm)	相电压 Rated Voltage (V)	相电流 Rated Current (A)	相电阻 Phase Resistance (Ω)	相电感 Phase Inductance (mH)	静转矩 Holding Torque (g.cm)	引线数 Lead Wire (NO.)	转动惯量 Rotor Inertia (g.cm <sup>2</sup> )	定位力矩 Detent Torque (g.cm)	重量 Motor Weight (kg)
39BYGHM207	0.9	26	12	0.5	24	13	1000	6	11	95	0.15
39BYGHM209	0.9	26	4.25	0.425	10	15	800	4	11	95	0.15

\*以上仅为代表产品，派生产品可根据客户要求制作。We also manufacture products according to customer's requirements.

### 外型图 Mechanical Dimensions

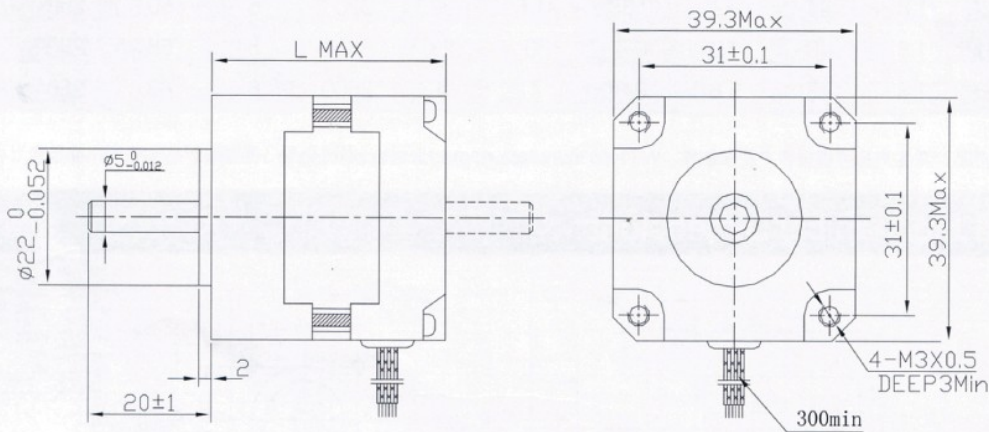

### 接线图 Wiring diagram

